



A division of Terry Young Ltd, New Zealand

## INSTALLATION INSTRUCTIONS for

# TOMMI

## WOOD BURNER

- Clean Air Sub 0.6 g/kg

**AUGUST 2023**

**TESTED in compliance with AS/NZS 2918: 2001 by Spectrum Laboratories Limited**

### **SAFETY INFORMATION**

#### **GENERAL:**

- This appliance is not intended for use by persons (including children) with reduced physical, sensory or mental capabilities, or lack of experience and knowledge, unless they have been given supervision or instruction concerning use of the appliance by a person responsible for their safety.
- For the protection of young children, install an effective fire safety screen around your fire. Always keep children well away from the wood burner when it is alight.
- Supervise young children to ensure they do not play with the appliance.
- During initial burns of the appliance, ventilate the rooms well. It is recommended that babies, small children, pregnant women and pets should not be present in the area during initial burns, as this is the firebox paint curing period.
- Do not make any modifications to the unit. Use it only in the manner described in the Operations Manual. Using it in any manner not recommended by the manufacturer may result in injury or death.

#### **FOR UNITS INCLUDING ELECTRICAL CONNECTIONS:**

- If the wood burner is permanently connected to an electrical source, an isolating switch (wall switch) must be installed.
- New circuits or modifications may be made, if required, but must be made using the services of a certified electrician only.
- Ensure that the outlets you use are grounded properly, polarised and provided with fuse units.
- Ensure that the electrical plug is accessible after installation. The wood burner must not be located immediately below an electrical socket. The socket should be located to one side of the wood burner. The electrical outlet should not be installed higher than 300mm maximum from the floor to the top of the plug socket outlet cover plate.
- Never operate the appliance with a damaged plug or cord. If you observe the fan unit is malfunctioning or the heater has been damaged in any way, call the authorised service person immediately for repairs, or to make electrical or mechanical adjustments. Isolate the electrical supply in order to alleviate any potential risk.
- If the supply cord is damaged, the manufacturer, its service agent or a suitably qualified person must replace it in order to avoid electrical hazard. Any cord similar to the original can be used.

## **IMPORTANT INFORMATION**

- I. It is imperative that you familiarise yourself with this entire document, and also ensure you have sufficient knowledge of relevant building regulations prior to proceeding with an installation.
- II. The appliance and flue system shall be installed in compliance with AS/NZS 2918:2001 and the appropriate requirements of the relevant building code or codes.
- III. Appliances installed in accordance with this standard shall comply with the requirements of AS/NZS 4013 where required by the regulatory authority i.e. the appliance shall be identifiable by a compliance plate with the marking “tested to AS/NZS 4013”.
- IV. Any modification of the appliance that has not been approved in writing by the testing authority is considered to be in breach of the approval granted for compliance with AS/NZS 4013.
- V. Mixing of appliance or flue system components from different sources, or modifying the dimensional specification of components may result in hazardous conditions. Where such action is considered, the manufacturer should be consulted in the first instance.
- VI. Cracked and broken components e.g. glass panels or insulation panels, may render the installation unsafe.

### **INSTALLATION:**

- A. Competent Trades Persons** are recommended to carry out all installations (e.g. a NZHHA Registered Installer), to obtain maximum performance and safe, efficient heating.
- B. A Consent** is required and we suggest you check with Local Authority Building Inspectors as by-laws do vary from area to area.

Also notify your Insurance Company that a solid fuel heater has been installed.

### **C. Floor Protector must:**

- a. Extend in front of the fuel-loading or ash-removal opening a minimum of 600mm.
- b. Extend at least 200mm from each side of the fuel-loading or ash-removal opening unless it forms an abutment with a wall or heat shield at a lesser distance.
- c. Be constructed of 2 sheets of non-combustible materials such as one of the following examples, or similar. The total combined thickness must not be less than 20mm.

Examples: Hilux (2 x 12mm), Eterpan (2 x 15mm), or Promatect-H (2 x 12mm).

- D. Seismic Restraint:** – Heater must be restrained from seismic movement as required by AS/NZS 2918:2001. 10mm diameter bolting holes in the rear corners allow restraint.

## E. Manufacturer's Recommended Tested Minimum Clearances From Combustible Walls:

Tested to AS/NZS 2918 : 2001 by SPECTRUM LABORATORIES LIMITED	Clearance
Rear Clearance (with YUNCA TOMMI FLUE GUARD fitted) from the fan	100mm
Side Clearance (with YUNCA TOMMI FLUE GUARD fitted)	400mm
Corner Clearance (with YUNCA TOMMI FLUE GUARD fitted)	400mm

## F. YUNCA TOMMI Flue Kit

**(Complies with AS/NZS 2918:2001 Appendix F): FIG A, B & E.**

1. 4.8m x 175mm stainless steel flue.
2. 3.6m x 225mm galvanised inner liner c/w brackets.
3. 3.6m x 275mm galvanised outer liner c/w brackets.
4. 1 x ceiling trim (500mm x 500mm)
5. 1 x liner support, drop box upper section.
6. 1 x drop box lower section.
7. 1 x weather cap & cowl.

**Please Note (1):** All flue joints must be sealed with flue sealing compound. Use stainless steel screws or rivets to join the active flue pipe (three equally spaced places at each joint). The first length of active flue must be fixed to the flue spigot on the burner with at least one stainless steel screw or rivet.

**Please Note (2):** The required minimum flue termination height is 4.6m above the floor protector when using the standard 200mm base unit. The minimum flue termination height will need to be adjusted (increased) if using a taller base.

## G. TOMMI WOODBURNER Flue Mounted Shield (Flue Guard) Kit. Complies (with heater) to AS/NZS 2918:2001): Refer FIG A.

- 1 x flue guard mount.
- 1 x 1200mm length, insulated, flat, back guard, plus an **optional** extension for trimming to length, as required.
- 1 x 1200mm length, "U" section, front guard, plus **optional** extension as required.

**Please Note:** The Tommi Flue Shield is to be full height within the room.

## H. TOMMI WOODBURNER Main Air Intake Assembly.

- 1 x Outer wall vent cowl.
- 1 x Air intake round duct
- 1 x Outer wall vent flange
- 1 x Damper duct assy.
- 1 x Flexi-duct. – [Optional. Not supplied]
- 2 x Flexi-duct clamp 100mm – [Optional. Not supplied]

## I. TOMMI WOODBURNER Fan Unit.

The fan **MUST** be operated on either high or low speed at all times. Failure to do so will result in excess heat, causing the thermostat to fail (and voiding the warranty on that part).

**FIG. A: HEATER DIMENSIONS – TOMMI WOODBURNER** (Not to Scale.)

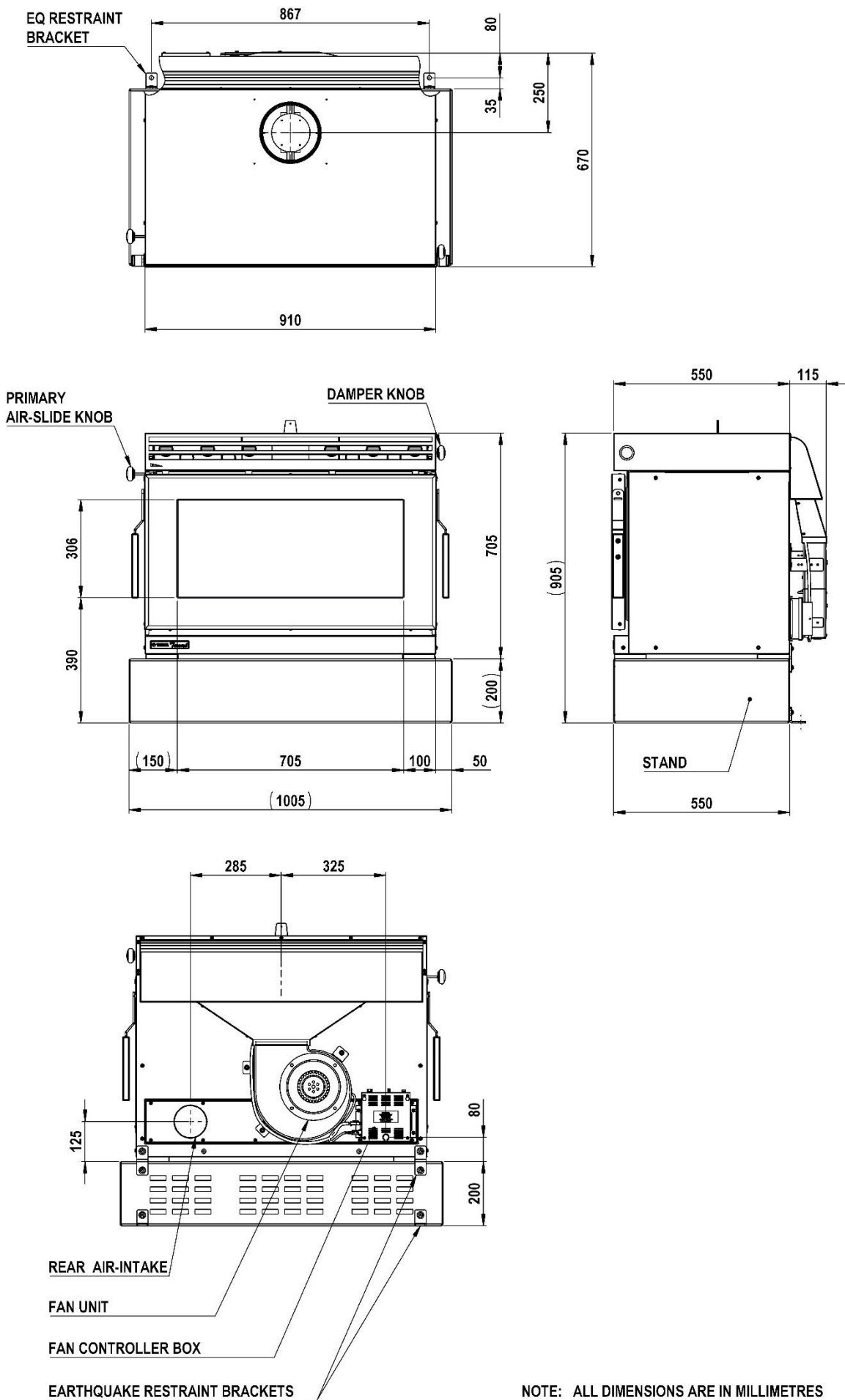

NOTE: ALL DIMENSIONS ARE IN MILLIMETRES

**FIG. B: HEATER POSITION – TOMMI WOODBURNER** (Not to Scale.)

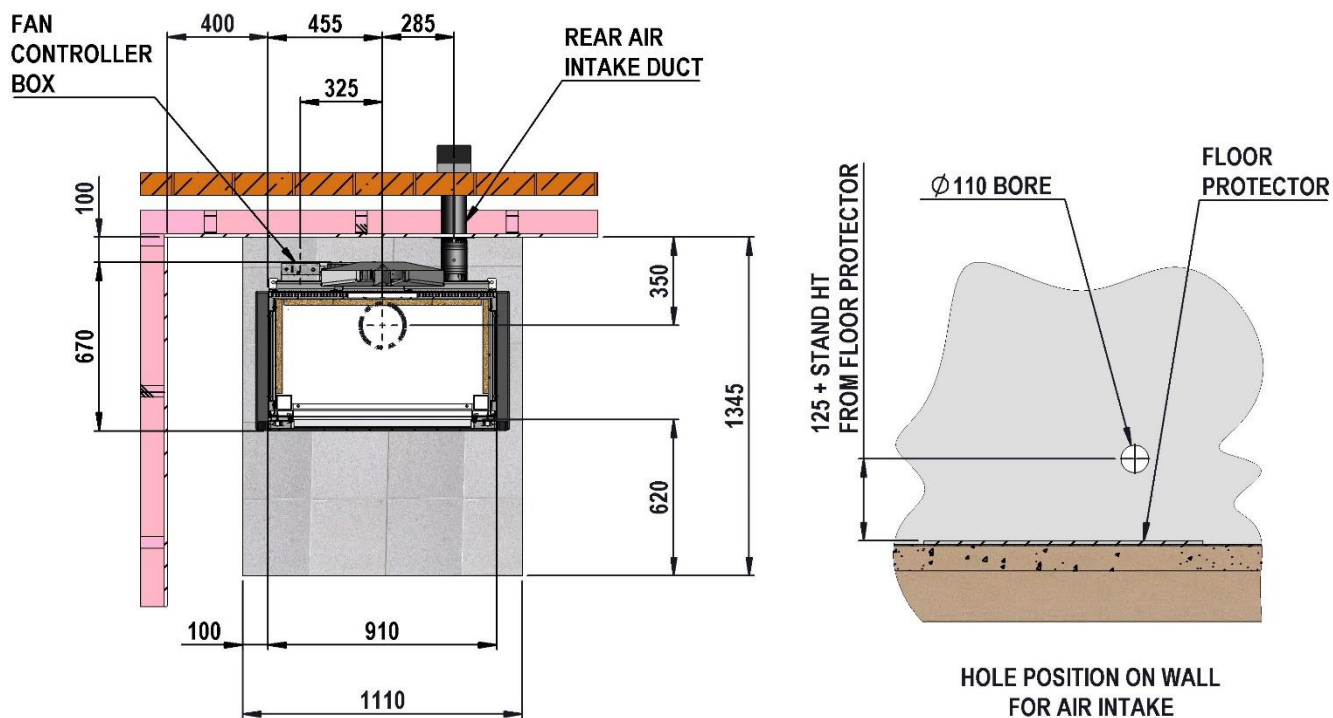

**PARALLEL POSITION CLEARANCE**

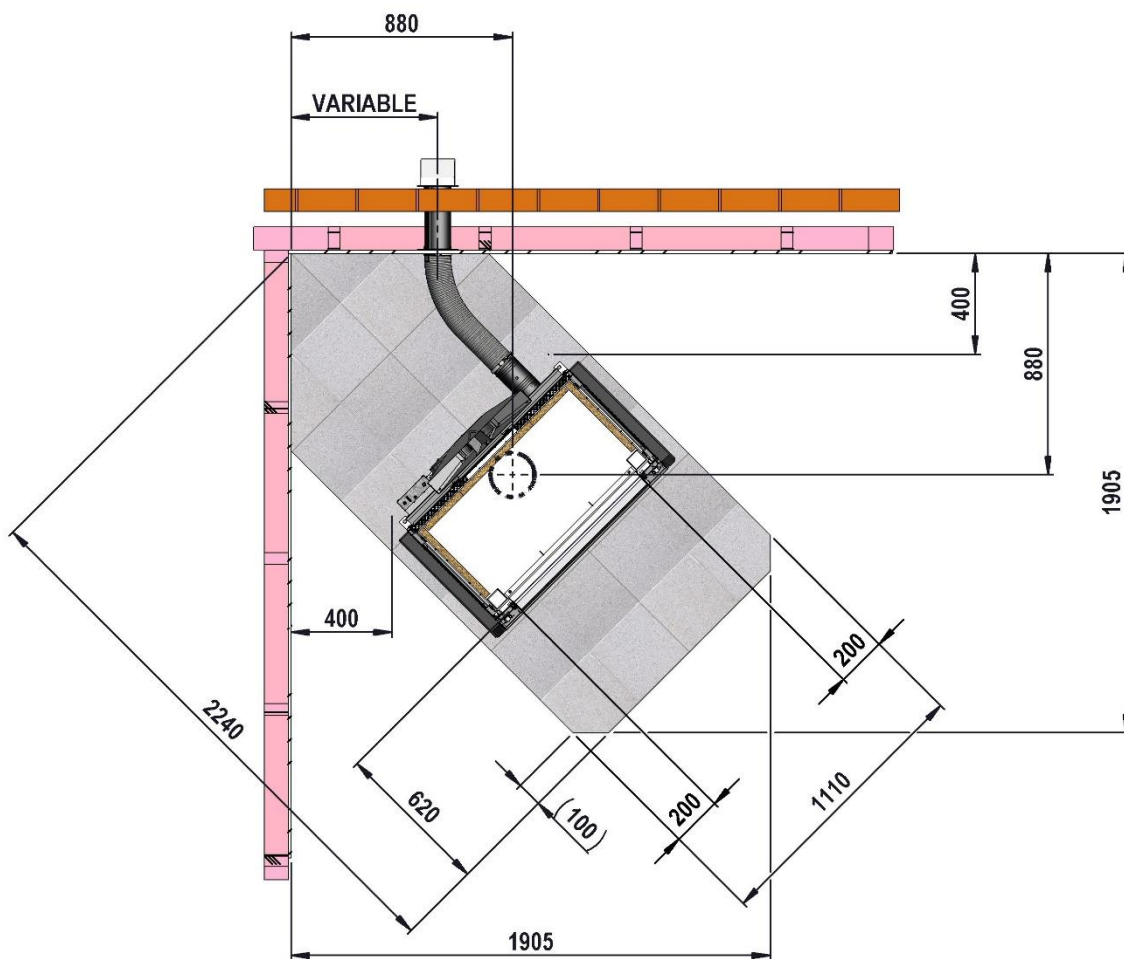

**CORNER POSITION CLEARANCE**

# FIG. C: TOMMI FREESTANDING WOODBURNER – TYPICAL FLUE INSTALLATION

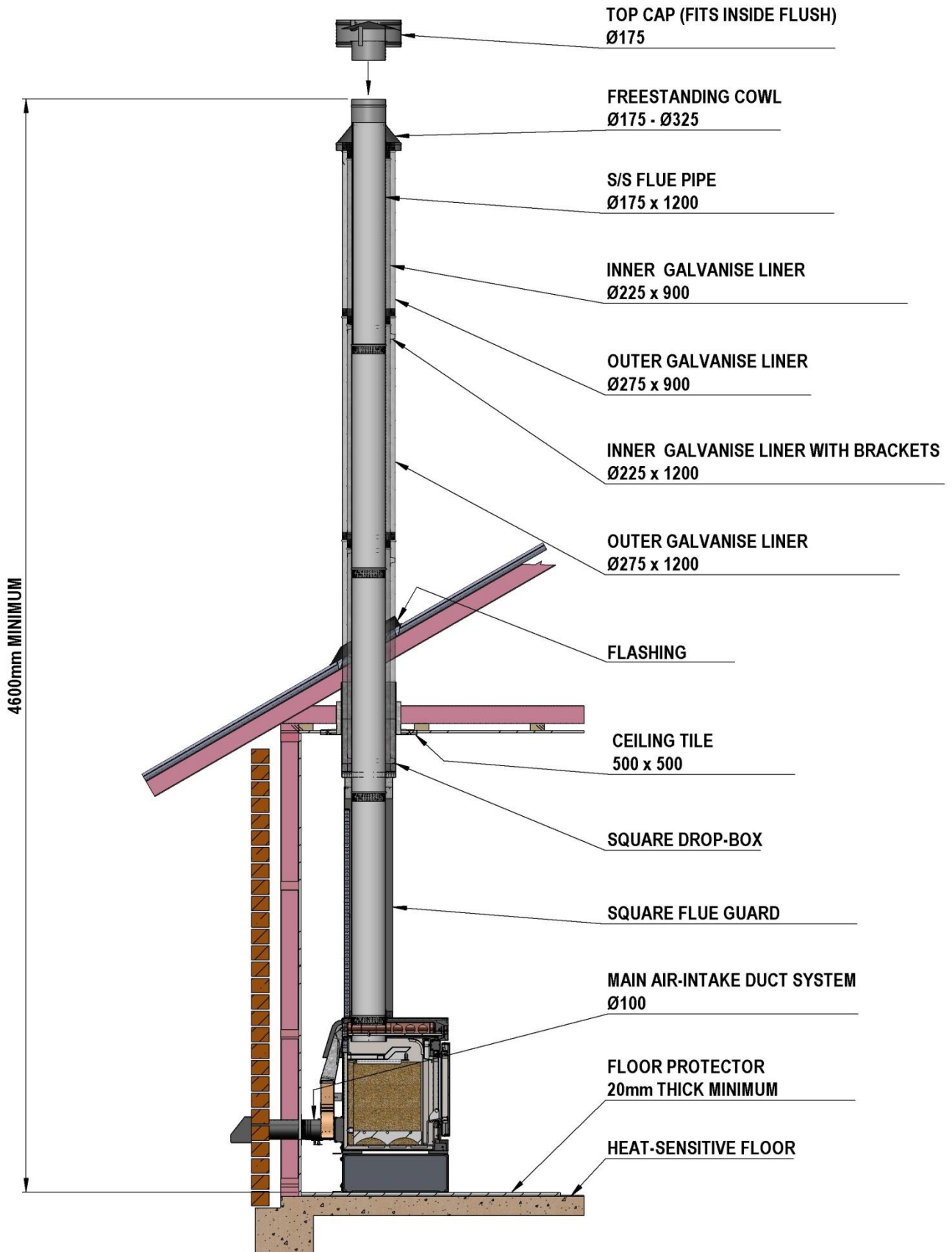

## **FIG D: FLUE SYSTEM REQUIREMENTS** (Not to scale)

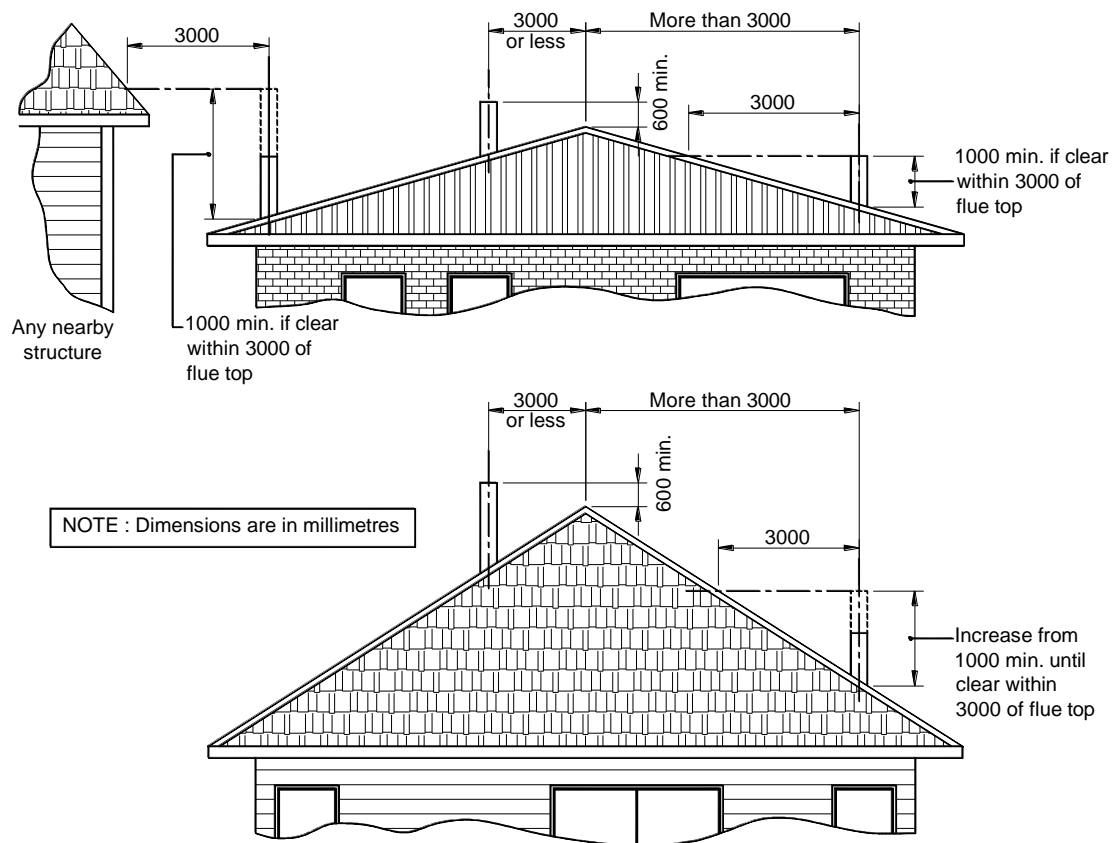

MINIMUM HEIGHT OF FLUE SYSTEM EXIT

### **IMPORTANT INFORMATION**

- A. THE APPLIANCE AND FLUE SYSTEM SHALL BE INSTALLED IN COMPLIANCE WITH AS/NZS 2918:2001 AND THE APPROPRIATE REQUIREMENTS OF THE RELEVANT BUILDING CODE OR CODES.**
- B. APPLIANCES INSTALLED IN ACCORDANCE WITH THIS STANDARD SHALL COMPLY WITH THE REQUIREMENTS OF AS/NZS 4013 WHERE REQUIRED BY THE REGULATORY AUTHORITY I.E. THE APPLIANCE SHALL BE IDENTIFIABLE BY A COMPLIANCE PLATE WITH THE MARKING “TESTED TO AS/NZS 4013”**
- C. ANY MODIFICATION OF THE APPLIANCE ,THAT HAS NOT BEEN APPROVED IN WRITING BY THE TESTING AUTHORITY, IS CONSIDERED TO BE IN BREACH OF THE APPROVAL GRANTED FOR COMPLIANCE WITH AS/NZS 4013**
- D. MIXING OF APPLIANCE OR FLUE SYSTEM COMPONENTS FROM DIFFERENT SOURCES OR MODIFYING THE DIMENSIONAL SPECIFICATION OF COMPONENTS MAY RESULT IN HAZARDOUS CONDITIONS. WHERE SUCH ACTION IS CONSIDERED, THE MANUFACTURER SHOULD BE CONSULTED IN THE FIRST INSTANCE.**
- E. CRACKED AND BROKEN COMPONENTS E.G. GLASS PANELS OR FIRE BRICKS, MAY RENDER THE INSTALLATION UNSAFE.**
- F. SEISMIC RESTRAINT:**
  - **Secure the heater base to the hearth or sub-framing with Dynabolts or similar.**
  - **Follow local Council’s Specifications.**

**FIG E: MAIN AIR INTAKE DUCT ASSY** (Not to scale)

Item Ref.	Drawing Number	Description	Corner Arrangement Parts Qty.	Parallel Arrangement Parts Qty.
1	0007400	100mm OUTER WALL VENT ASSEMBLY	1	1
2	0007393	100 x 600mm S/S INLET DUCT	1	1
3	0007402	OUTER WALL VENT - FLANGE	1	1
4	0007338	AS 4-2 BLIND RIVET	3	4
5	0007440	100mm STAINLESS INLINE DAMPER	1	1
6	0007399	FLEXI-DUCT (Optional)	1	-
7	0007405	HOSE CLAMP SS 90-110mm (Optional)	2	-

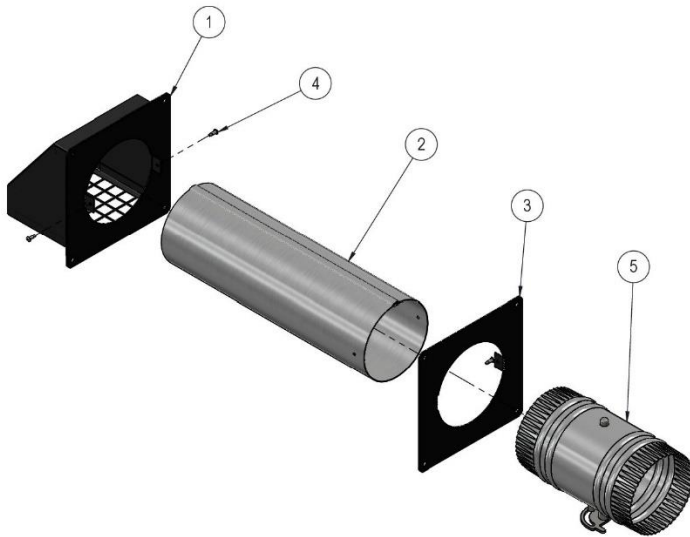

**Note:**

1. WHEN CHOOSING ALTERNATIVE VENT COWL OR PIPES, TOTAL VENT OPENING AREA MUST BE NO LESS THAN 7854 mm<sup>2</sup>
2. USE 8G x 30 CONCRETE / GIB SCREWS TO MOUNT THE COWL AND WALL PLATE ON THE WALL.
3. USE ALUMINIUM FLEXI-DUCT TO EXTEND CONNECTIONS BETWEEN THE STAINLESS DUCT AND THE DAMPER.
4. ALL PARTS MUST BE PAINTED HIGH TEMPERATURE METALLIC BLACK

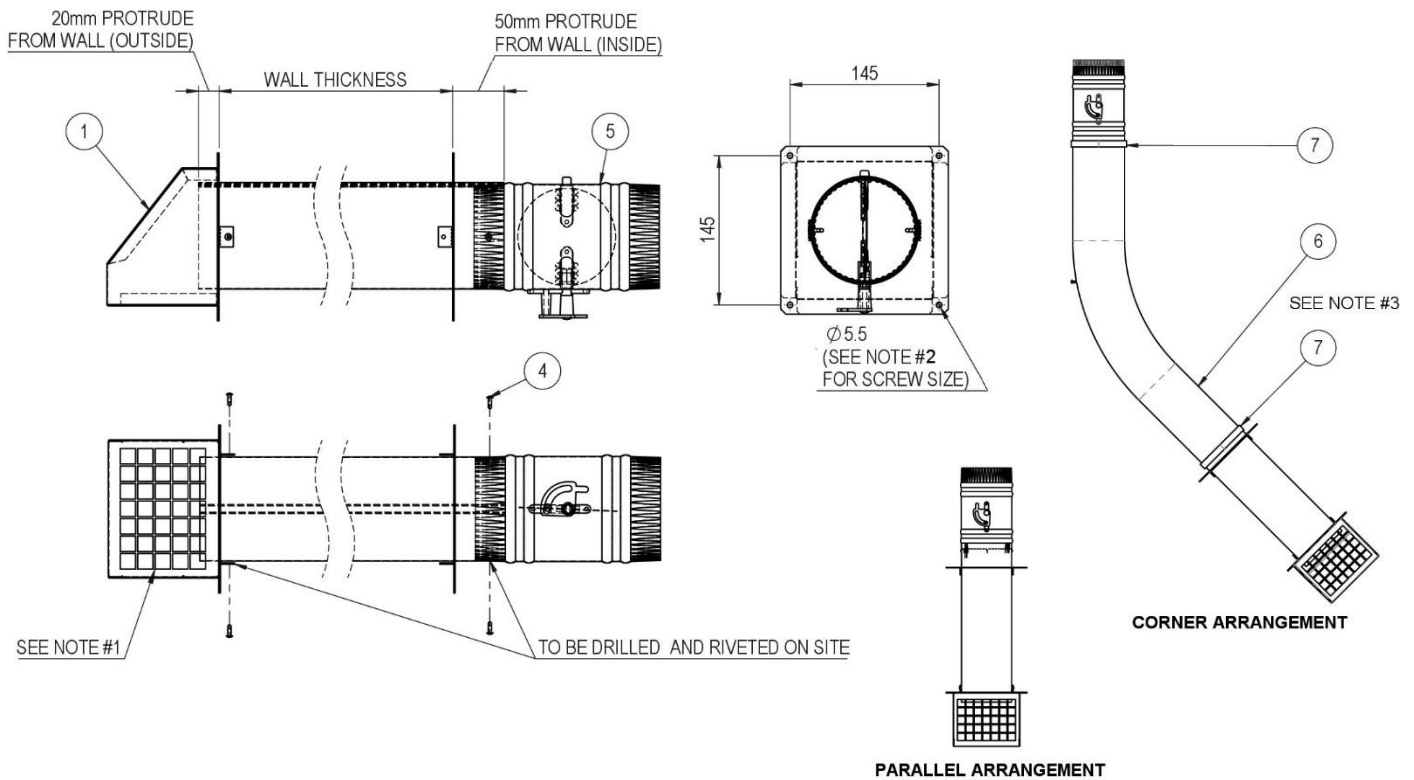



# Yunca Tommi Flue - Installation

1. With the Tommi fire to hand (Preferably in the room) mark the positions of the external air supply hole and the seismic hold downs. Confirm against the actual Tommi. If there is a severe clash with a column or stud, the air inlet position may be swapped about the centreline of the fire by removing the rear panel and reversing it. You may find it easier to cut the hole for the air inlet and drill the holes for the seismic fasteners before positioning the fire in place.
2. Determine the position of the centre of the Tommi flue horizontally in the room. Mark this on the floor. Confirm with everyone concerned that this is where the fire should sit.
3. Transfer this floor position mark to the ceiling directly above using a plumb bob, laser or other means. Mark a line from this point up and down the slope of the ceiling and a line through the point across the slope forming a cross.
4. Accurately determine the actual slope of your ceiling. Using the numbers from the supplied "Ceiling Tile Frame Cut Out" chart, mark out the rectangle on the ceiling. (Views are taken from inside the room, looking up. The ceiling is "see through".)
5. Ensure that the flue will miss ceiling and roof support members. The minimum rear clearance for the Tommi fire is 100mm from the wall to the fan housing, at the rear of the fire. If the fire is being set up parallel to the wall, this clearance will be achieved with a distance of 350mm from the wall to the centre of the flue. (See Fig. 1 below).

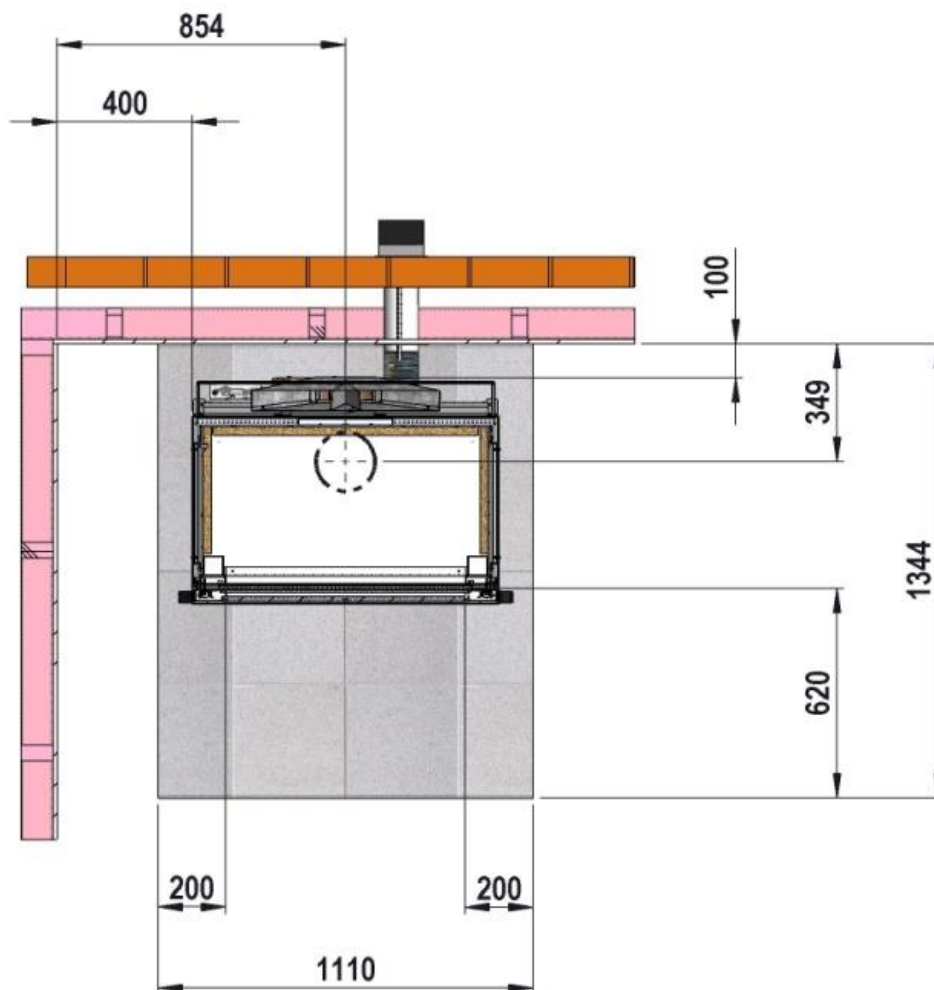
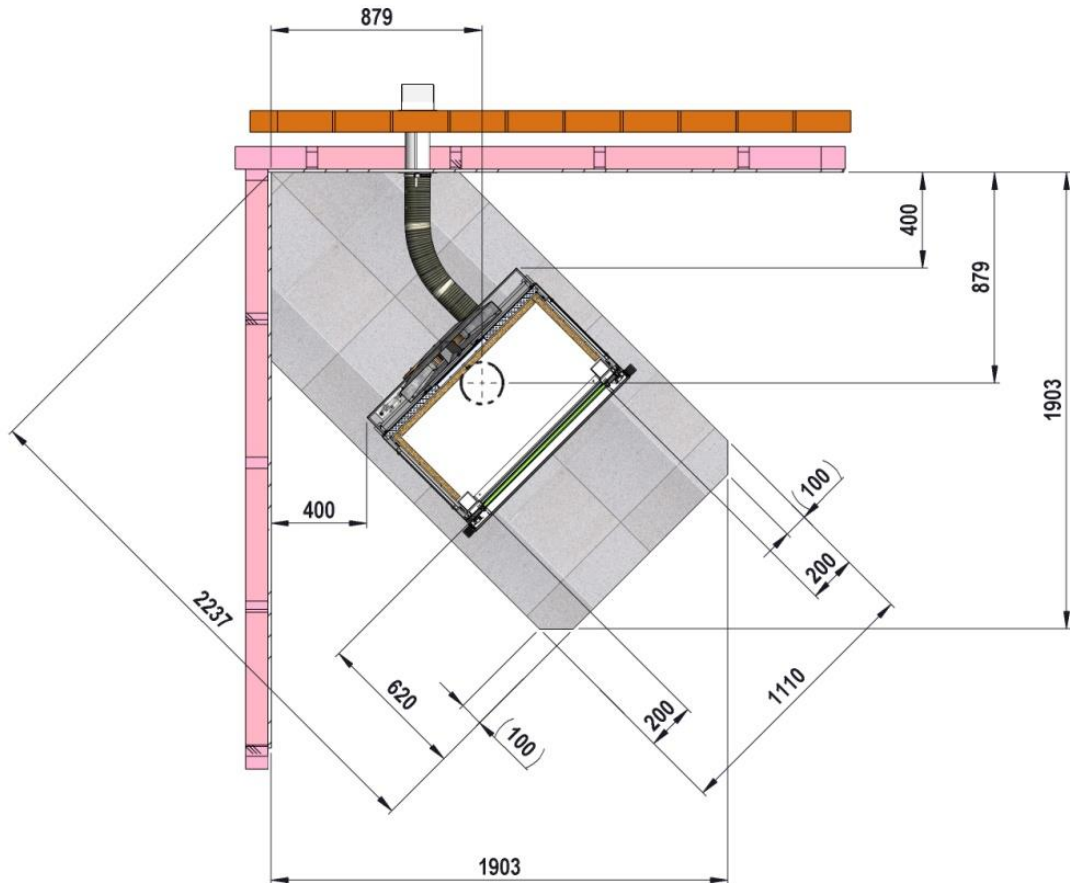
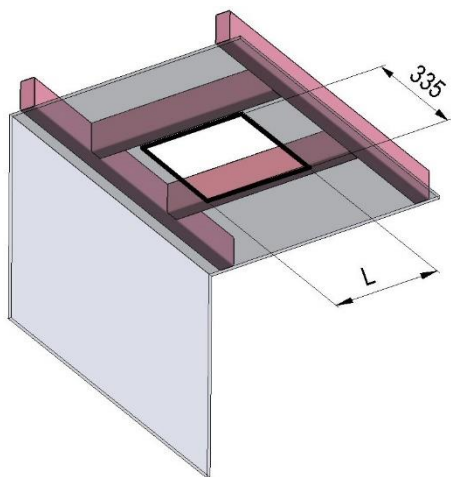

Fig 1 – Plan View - Tommi Installed Parallel to Main Wall

6. If the fire is to be set up to be diagonally across a corner, the minimum clearance to the walls at each side is 400mm. This is achieved with a parallel distance from each wall to the centre of the flue of 879mm. (See Fig 2 below).



**Fig 2 – Plan View – Tommi Installed Diagonally**



ANGLE	OPENING		
	W	x	L
0	335	x	335
5			335
10			340
15			345
20			355
25			370
30			385
35			410
40			435
45			475

**Fig 3 – Sloped Ceiling – Frame Opening Dimensions**

- Unpack the Ceiling Tile Frame and confirm that the notched out arrows, four positions, align with the laser cut numbers for the actual slope of your ceiling in degrees. (E.g. 10 degrees being halfway between “0” and “20” degrees.) Loosen the clamping/retaining screws and make any necessary adjustments until the frame is sized to match the slope of your ceiling.

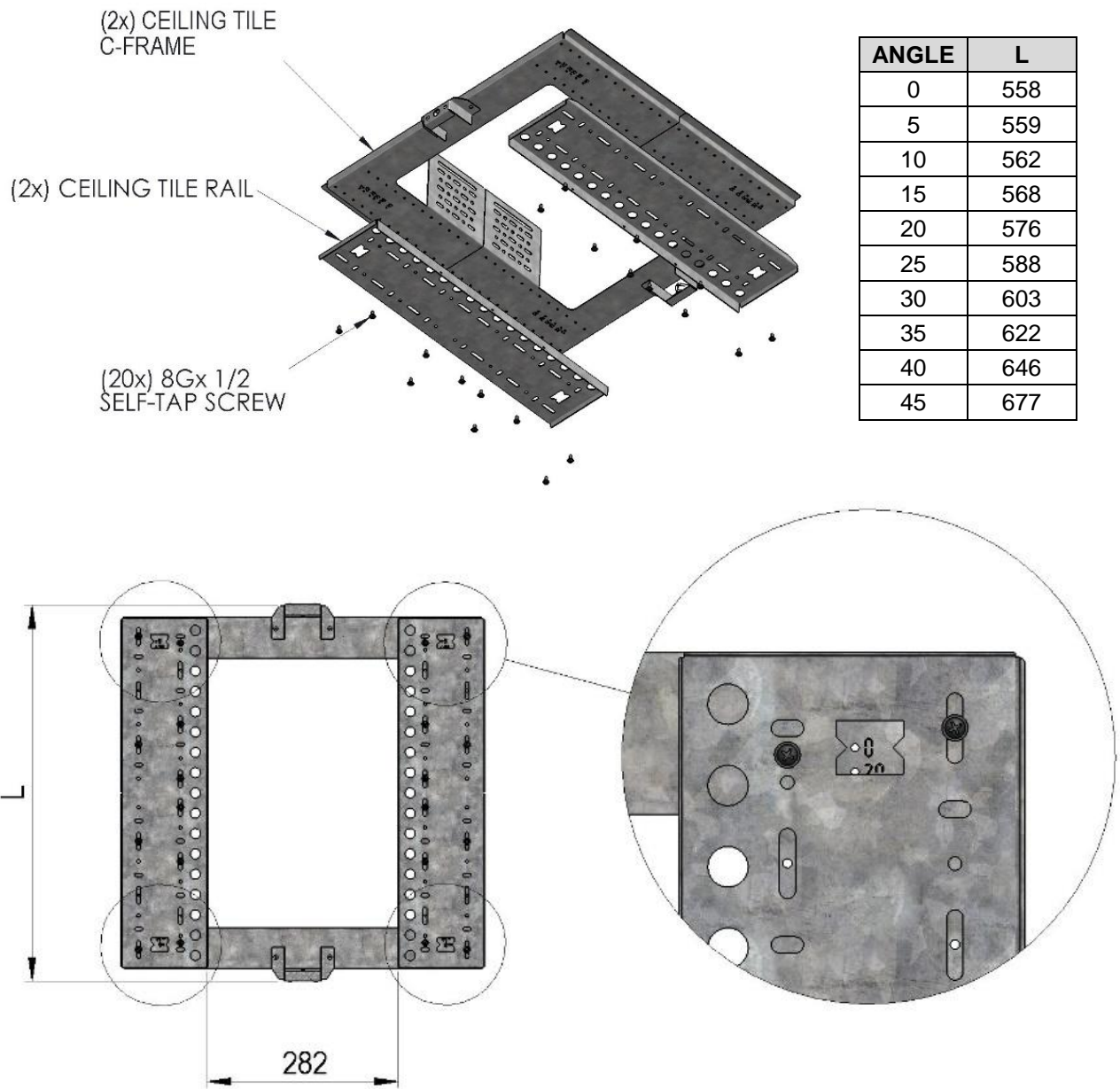

**Fig 4 – Sloped Ceiling - Angles**

- Confirm that your rectangle marked out on the ceiling will take the correctly adjusted Ceiling Tile Frame, and is correctly positioned up and down slope.
- Cut out the ceiling rectangle. - You can cut around the outside of the line.
- Confirm the Ceiling Tile Frame will fit in the hole and looks appropriate.
- Frame out the sides of the cut-out from within the room, or from the ceiling cavity (if you have access) to support the sides of the Ceiling Tile Frame when installed.
- Install the Ceiling Tile Frame up against the ceiling and attach it to the blocking, using screws through the long slots in the predrilled/slotted mount tabs (You may yet wish to slide the Ceiling Tile Frame up or down the slope of the ceiling). Caution: The edges of the frame are sharp.

13. Take the painted Drop Box and conduct a trial fitting of it up into the Ceiling Tile Frame. Confirm that:
  - 13.1. It can be made vertical. (Perpendicular to the floor.)
  - 13.2. It can be positioned at the correct height vertically to cope with: Floor Protector + height of Plinth + height of Tommi + length of available Flue Guard and still have the Flue Guard lap neatly onto the lower portion of the Drop Box.
  - 13.3. Leave a 10mm space between the top of the flue guard and the shoulder of the drop box, to allow for heat expansion.
  - 13.4. The Drop Box is centralised over the floor mark position for the fire.
14. Mark the midpoint of each side of the Drop Box and use masking tape across to find the centre.
15. Check position with plumb bob or laser etc. You have some latitude to enlarge the hole and move the Ceiling Tile Frame up or down the ceiling slope as required. You may temporarily install the two halves of the Ceiling Tile – as described below – to determine where the Drop Box has to sit.
16. Put a couple of temporary screws through the centre holes of the Drop Box and Ceiling Tile frame flanges, allowing for perpendicular adjustment front to back (**Caution:** These centre screws must be removed once rivets are fixed in the outer holes, as they would otherwise inhibit the flue from sitting in the proper position).
17. Mark position of Drop Box relative to Ceiling Tile Frame – vertically and up and down slope.
18. When everything is positioned correctly, remove Drop Box and permanently install Ceiling Tile Frame with 3 screws through round holes in each tab, each side into blocking timber.

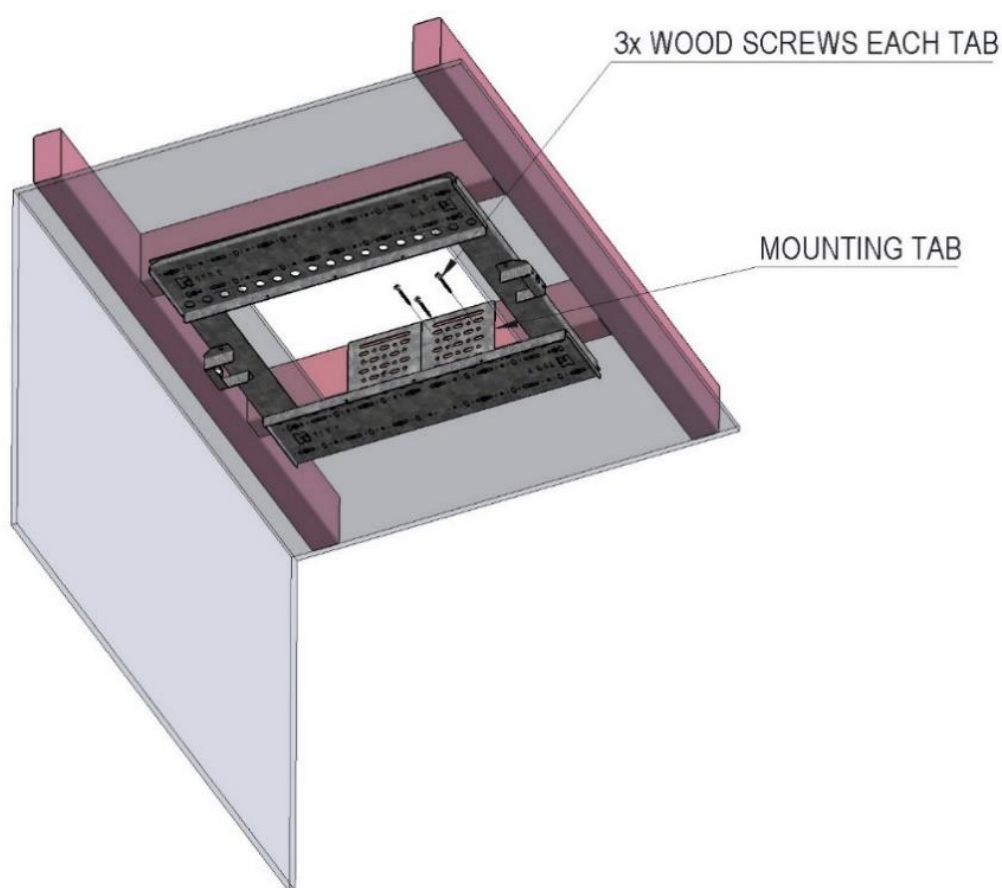

Fig 5

19. Reinstall Drop Box to marked position, confirm vertical, correct height and centralised and fix in place using rivets through predrilled holes in side flanges of Ceiling Tile Frame both sides.

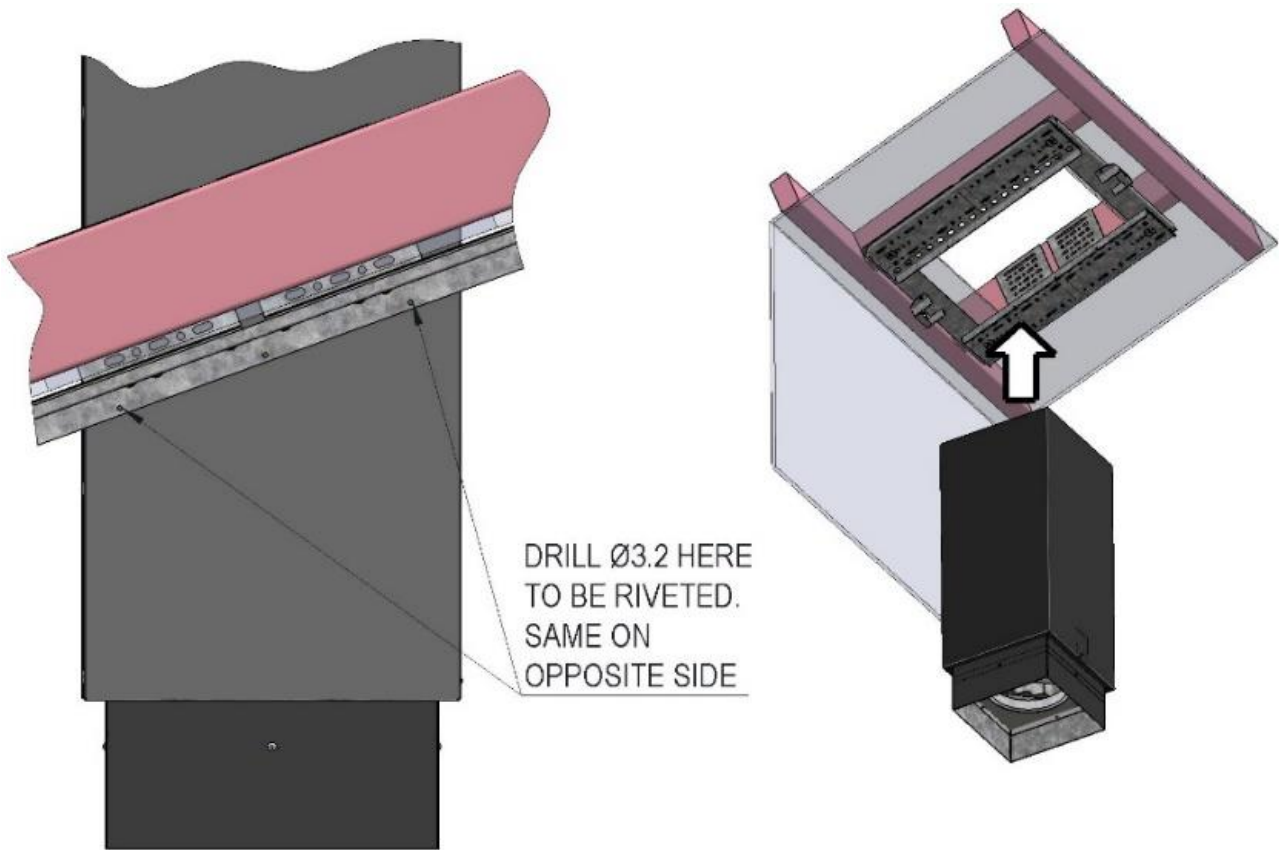

Fig 6

20. Remove temporary screws from centre holes once rivets have been fixed in place (in outer holes).
21. Place the Inner REAR Ceiling Tile in position against the Ceiling Tile Frame from the down slope side of the flue (or the side closest to the wall) and press push pin into the socket (Note: There is no sliding flange on rear/inner ceiling tile – it may droop slightly).
- 21.1. Slide the Outer (upper) Ceiling Tile into the slots of the Ceiling Tile Frame on the upper side of the flue. Move the two halves together such that the outer half slides over the inner.
- 21.2. Once you have the inner half captured inside the outer, push the two halves firmly together so the push pins on both halves engage in their sockets.

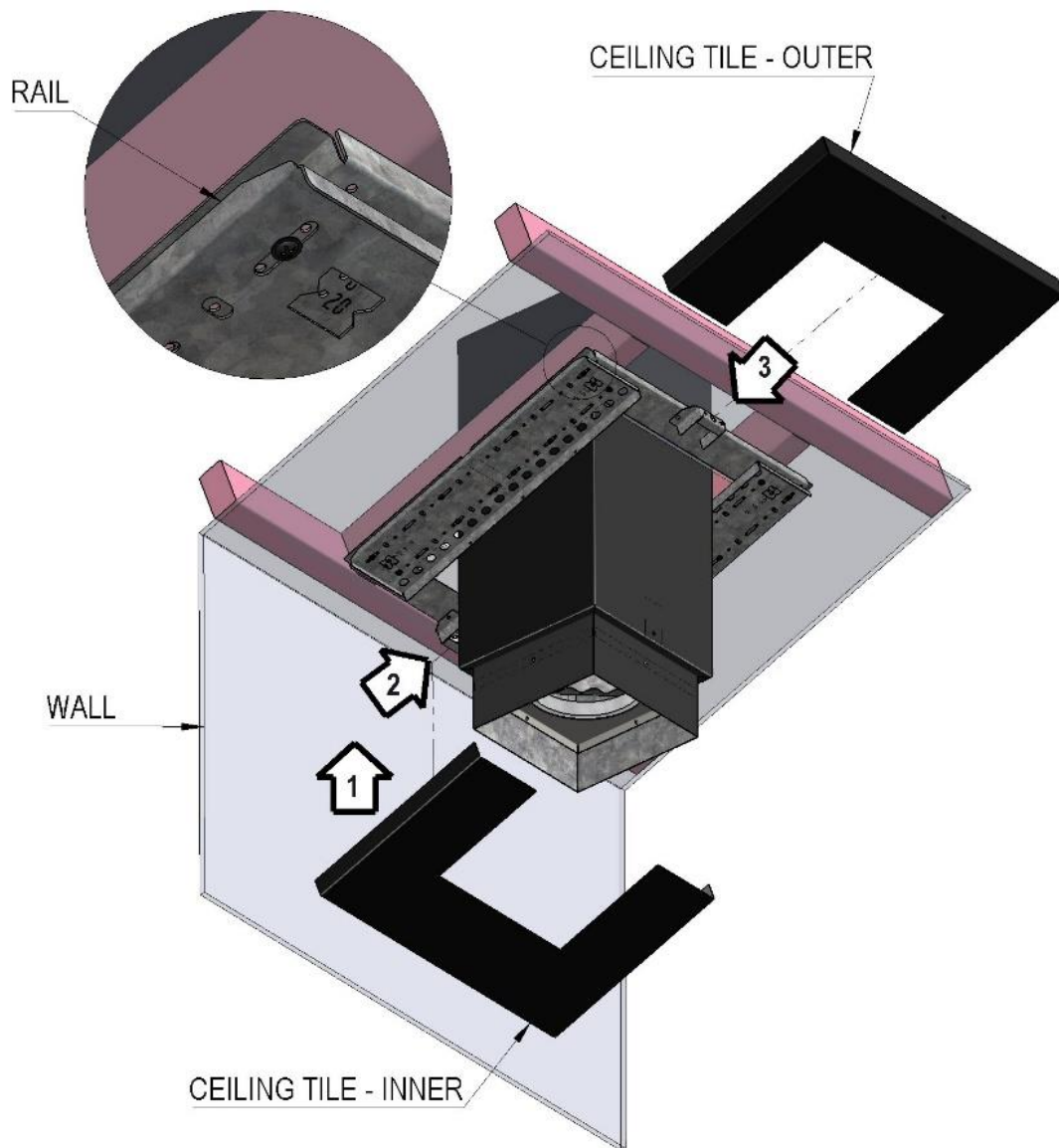

Fig 7

22. Establish the centre point of the flue on the roof above and cut a clearance hole for the outer liner.
23. Lower the **first section of Inner Liner** down through the roof and insert it into the saw toothed, square support frame in the Drop Box.
24. Lower the **first section of Outer Liner** down through the roof over the Inner Liner and insert it into the Drop Box. Drill and place a rivet or screw through the Drop Box and Outer Liner, on all four sides, where the Liner touches the Drop Box. You can do this from within the ceiling cavity, above the ceiling, if you have access, otherwise do it from within the room below the ceiling.
25. **IMPORTANT:** Before installing any more sections of Liner and while you can still see the spacers, connect the first sections of Inner and Outer Liner together by drilling right through the Outer Liner and spacers and installing screws or rivets. This connects the Liners together and prevents the Inner Liner from moving out of place during any wind or seismic events.
26. Complete Liner install and install flue.
27. Install Tommi Flue Guard over flue within the room, lapping it over base of Drop Box and fastening to it.
28. Install any remaining parts; Flashing around Outer Liner, Flue Cowl, etc.