



LEEDZ FREE STANDING

GAS HEATER

July 2001

OPERATIONS, MAINTENANCE & WARRANTY INFORMATION

CONTENTS:	PAGE
INTRODUCTION	3
INSTALLATION	4
FLUE INSTALLATION	5
CLEARANCES	6
CONNECTION TO GAS SUPPLY	7
TESTING PRESSURES	8
OPERATION	9
MAINTENANCE	11
FAULT FINDING GUIDE	15
Appendix A GAS TYPE CONVERSION	18
Appendix B PARTS LIST	20
Appendix C INJECTOR SIZES	20
Appendix D WARRANTY, WIRING DIAGRAM	21
Appendix E WARRANTY REGISTRATION	22

INTRODUCTION

Welcome and congratulations on purchasing your YUNCA LEEDZ FLUED GAS HEATER.

Please read the following carefully before attempting to operate the heater and ensure all members of your home understand how this elegant and highly efficient heater functions.

Please fill out and return the registration card promptly.

These instructions should be stored in a convenient safe place for ready reference. If you have any questions regarding your heater please contact your YUNCA LEEDZ dealer.

The YUNCA LEEDZ FLUED GAS HEATER is a listed gas-fired, conventionally vented, room heater tested by independent laboratories to Australian and New Zealand standards.

The installation of the YUNCA LEEDZ FLUED GAS HEATER must be carried out by a suitably qualified person and comply with the current New Zealand or Australian installation code, NZS 5261:1996/ AG 601:1998

CAUTION: This appliance must be flued to atmosphere. Installation and repair of the YUNCA LEEDZ VENTED GAS HEATER should be done by a qualified person. The appliance should be serviced at least annually by a qualified service person. Control valve compartments, burners, fan, and air circulating passageways of the Leedz must be kept free from any lint and dust build-up to ensure efficient and safe operation of the heater.

DO NOT PLACE ARTICLES ON OR AGAINST THIS APPLIANCE.

DO NOT USE OR STORE FLAMMABLE MATERIALS NEAR THIS APPLIANCE.

DO NOT SPRAY AEROSOLS IN THE VICINITY OF THIS APPLIANCE WHILE IT IS OPERATIONAL.

To remove internal packaging, refer to page 12 for front door removal.

INSTALLATION

Considerations

The most desirable and beneficial location for a YUNCA LEEDZ HEATER is in the centre of a building, thereby allowing the most efficient use of the heat created.

The location of windows, doors and the traffic flow in the room where the heater is to be located, should all be considered.

If possible a location should be selected that allows the flue pipe to be installed simply and pass through the house without cutting a floor or roof joist.

To obtain maximum heat distribution with any freestanding heater a ceiling fan can be fitted.

Another important consideration when installing the Yunca Leedz is availability of power supply to the fan.

When the appropriate position has been selected the unit can be bolted to the floor to ensure that the unit remains upright in the event of an earthquake or similar. If the heater is being attached to a concrete floor dyna bolts should be used, if the floor is wooden the bolts used should be long enough to go fully through the floorboards and fixed with nuts and washers from the underside.

The earthquake brackets are located at the rear corners of the heater.

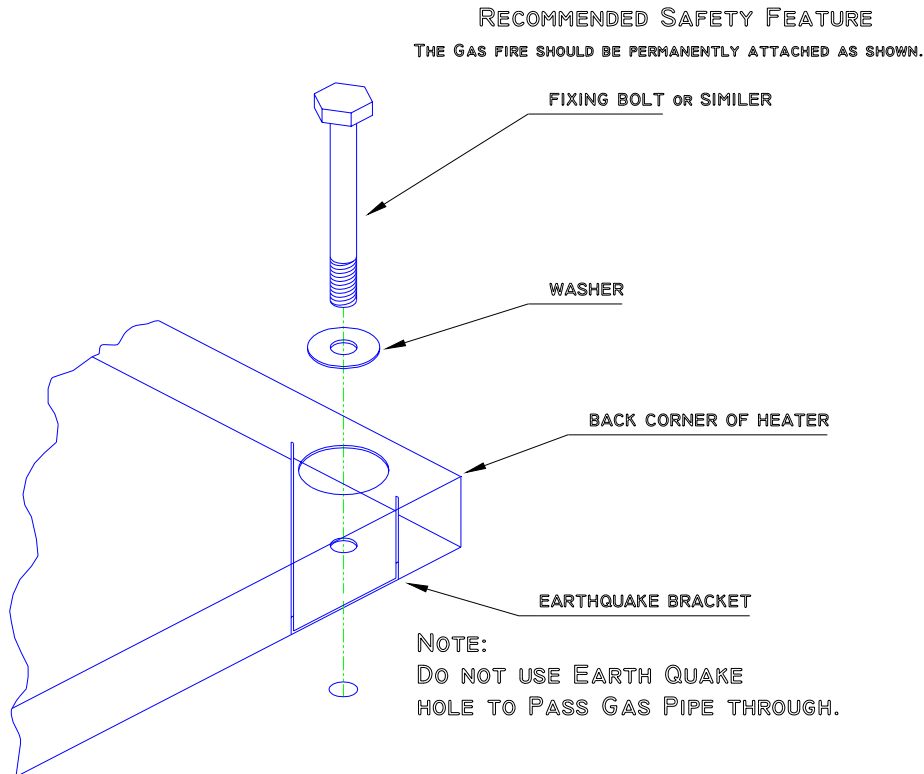

Typical Flue Installation

ANTI DOWNDRAFT COWL

100mmØ STAINLESS STEEL



CEILING TII

100mmØ ENAMELED OR STAINLESS STEEL FLUE.



CLEARANCES

The YUNCA LEEDZ FLUED GAS HEATER should be installed with clearances equal to or greater than those recommended below and comply with NZS 5261/ AG601. This is to ensure adequate air circulation around the heater and avoid heat damage to wall coverings.

Note: If walled surface is incombustible i.e. brick or steel, side clearances may be reduced by 100mm, and the back clearance to a minimum of 75mm. Corner positions remain the same.
(See Fig. 3 Below)

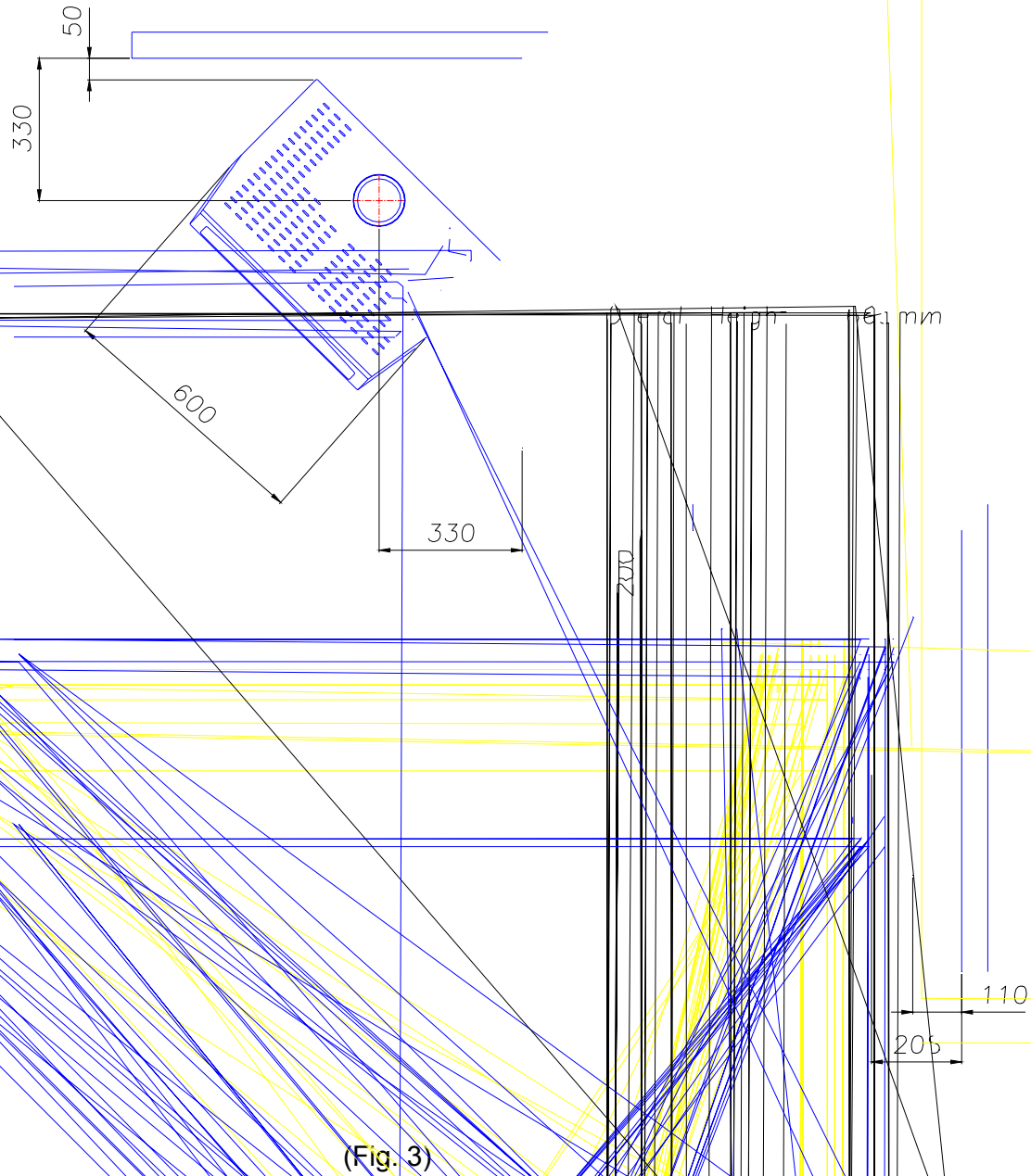

CONNECTING THE HEATER TO A GAS SUPPLY.

Burn only the fuel for which the heater is equipped.

The YUNCA LEEDZ may be shipped from the factory equipped to burn Natural Gas, Propane or L.P.G. The data plate affixed to the back of the heater specifies the gas type which the heater is factory equipped for. Fuel Conversion Kits, No. LZ-A16 for natural gas, or Kit No. LZ-A15 for L.P.G. are available from your YUNCA agents.

See Appendix: A for instructions on field conversion from one gas to another. This conversion can only be done by a suitably qualified person.

Thermostat:

Remove the thermostat sensing bulb through access panel at base of back panel. The bulb should be placed under the saddle on fan Assembly.

Gas connection:

The gas inlet is located through the back panel, into the base of the control. The inlet thread is a female 3/8" BSP and is accessed by removing the two inspection covers. A separate gas isolation valve should be installed immediately up stream of the connection to the appliance.

WARNING: To stop pipe compounds entering the gas line, do not apply sealing compounds to the first two threads at the tip of any gas connection. All joints should be tested for leaks before operating the heater.

GAS PRESSURE REQUIREMENTS

Correct gas pressure and the use of a properly sized gas supply line is essential for the safe and efficient performance of this appliance. The inlet and outlet pressures at the control must be tested on installation following the procedure over page.

Note: Improper gas pressure will affect heater performance flame colour or cause pilot malfunction.

Natural Gas:

Minimum inlet pressure	1.25 KPa (5"w.g.)	{For Australia 1.13Kpa}
Maximum inlet pressure	5.0 KPa (20"w.g.)	With supplied inline regulator fitted.
Operating pressure	1.0kPa (4"w.g.)	{For Australia 0.8 KPa}

L.P.G. (NZ Only) and Propane

Minimum inlet pressure	2.75 KPa (11"w.g.)
Maximum inlet pressure	3.5 KPa (14"w.g.)
Operating pressure	2.5 KPa (10"w.g.)

CAUTION: Do not use this heater if any part has been under water or exposed to moisture causing corrosion.

A Qualified service technician should inspect the heater and replace any part of the gas system that has been under water.

PRESSURE TESTING:

The pressures listed on the previous page can be tested using a manometer.

To attach manometer, first remove the inspection cover from back panel. The cover is located directly behind the control and is removed by unscrewing the two top screws.

This will expose the back of the control so manometer tubes can be attached to the pressure taps as shown below.

The inlet pressure can be adjusted via in line regulators in the supply to the heater, and the outlet (operating) pressure by adjusting the valves internal regulator. To locate the valves regulator adjustment screw the plastic control cover must be removed from the front of the valve. This is done by removing the bottom screw and inserting a small flat head screwdriver into the slot at the top on the front of this cover and pulling the cover off.

Refer to fig. 4 below

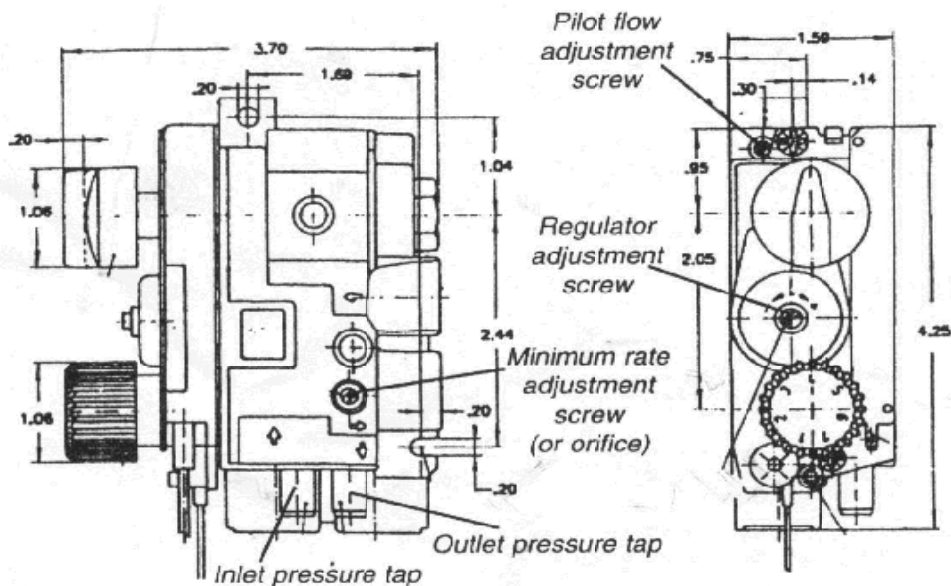

CONNECTING THE FAN

The fan should be connected to the mains supply (240V 50Hz) via the 3m flex and 3pin plug provided.

OPERATION

How To Light Your YUNCA LEEDZ

Refer to Fig 5.

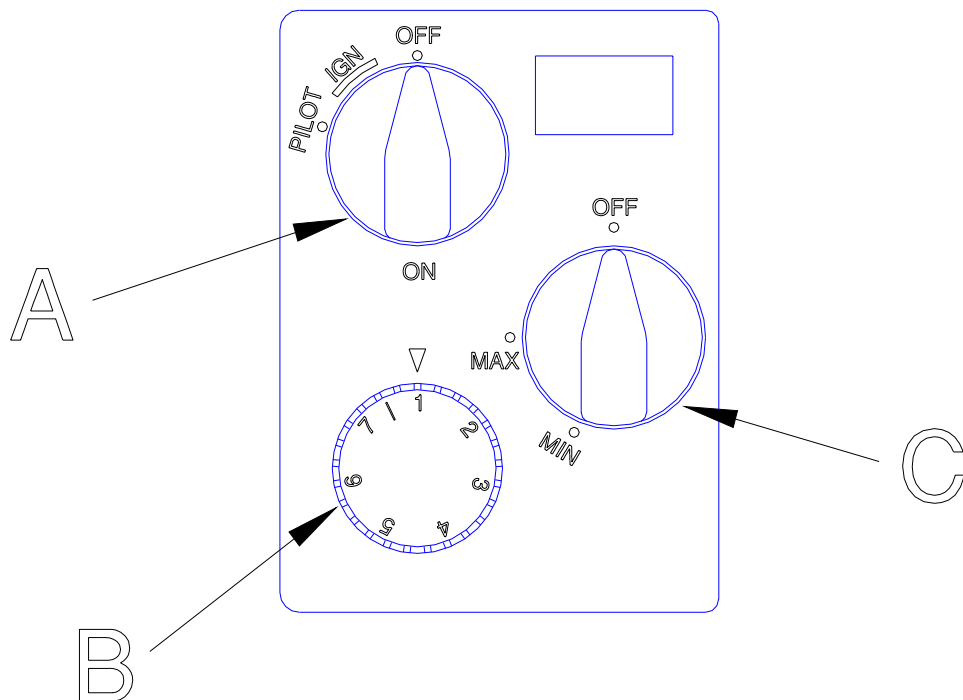

Fig 5: Control Panel.

1. First read all the instructions for the heater.
2. Check that the control knob "A"(Fig 5) is in the off position, the thermostat knob "B" is turned to its Highest setting (7) and back burner control "C" should be in the off position.
3. Turn off electric power at the wall.
4. Turn the knob "A" slightly anti-clockwise to stop. Push the control knob "A" fully down and turn left from OFF to IGN, hold for 5-15 seconds. Continuing to hold down, turn the knob "A" further anti-clockwise to pilot mark. Observe pilot light by looking through front door. The pilot light is visible under the left-hand end of the log set.
5. When the pilot is lit, continue pushing in knob for further 20 seconds to allow safety thermocouple to heat up. Release knob and pilot flame should remain lit. If it goes out repeat steps 4 and 5
6. The pilot control knob "A" can now be turned fully left to the ON position to light the front burner.
7. Turn electric power on and the fan to low speed.
8. After the front burner has been on for at about 3 minutes. Turn the back burner on, by pushing in knob "C" and turning Anti-Clockwise to maximum position.

Allow both burners to run for 30 minutes to bring the room up to temperature.

9. Turn the back burner off.
10. Adjust the thermostat down, to the front burner turns off. Note the thermostat number and turn up by $\frac{1}{2}$ to $1\frac{1}{2}$ a thermostat number till the front burner turns on.
11. Leave the fan on. Note Fan can be turned off, Higher efficiency is achieved with the fan running

To further increase the room temperature follow the following steps:

- 1st Turn the fan on to high speed.
- 2nd Turn the thermostat up one number.
- 3rd Turn the secondary burner on to minimum.
- 4th turn the secondary burner up to maximum.

Note: Various combinations of the settings of knobs “B” and “C” will provide different heat settings and flame effects.

The first few times that the heater is lit it should only be running for about twenty minutes. And then allowed to cool. This will eliminate damage to paints and reduce the smoke and odour caused by burning off of manufacturing oils etc.

HOW TO TURN OFF THE HEATER.

1. If the thermostat, knob “B”, has been in use turn it to its lowest position.
2. Turn the rear burner control, knob “C”, to the off position.
3. Turn off the electrical power at the wall.
4. Push in the pilot control knob “A” and turn it clockwise to off.

Note: the knob cannot be turned from “pilot” to “off” unless it is pushed in slightly.
Do not force it.

MAINTENANCE

A qualified service person recommended by your YUNCA dealer should conduct an annual inspection and undertake any maintenance required on your LEEDZ. Its venting and installation must be checked to keep it running safely and efficiently. The following procedures should be performed only by a qualified service person. The gas supply and electrical power should be isolated whenever any maintenance procedures are undertaken.

Note: the door can only be removed after the heater has been turned off for long enough so that the door has cooled to touching temperature.

Removing The Front Door

1. First the side panels must be removed, to do this grip panel at its base and pull out. The panel should be swung out to about 30 degrees and then pulled down to release the locating pins in its top.
2. This will expose the restraining latches at each side. To open these latches lift the butterfly grip forward and twist it through 180 degrees.
3. The front door can now be removed by gripping it by its back bottom corners and pulling it straight back and out.
Note: It is important not to spread the sides out any further than is necessary to remove door, as this may damage the doors enamel coating

Removing The Glass For Replacement.

1. Remove the front door as described above, and place front down on a soft surface.
2. Remove the two side glass retainers by taking out the three bolts in each one.
3. Remove the bottom front glass retainer by taking out the four screws along the base of the door.
4. To remove the front glass place one hand under it and lift it up and out of the doorframe.
5. Remove the side glasses
6. New glass with gasket attached can be ordered through your YUNCA LEEDZ agent.
Note: Only recommended heat resistant glass may be fitted.
7. Place replacement glass in position in the reverse order of removal, i.e. Side glass should be placed in position before front glass.
8. Replace side and bottom glass retainers with their respective bolts and screws.
Note: Tighten the screws and bolts alternately, do not over tighten to avoid damaging glass.

REPLACING THE GASKET.

The YUNCA LEEDZ has a 10mm fibreglass gasket surrounding the front door. Should it ever need replacement, use only the replacement gasket that is available from your YUNCA dealer. The reference number for this is listed in the parts list.

Procedure.

1. Remove the front door as described on previous page.
2. Remove the existing gasket and clean the channel of all loose material.
3. Lay a thin bed of gasket cement around the length of the channel.
4. Lay the gasket in the channel.
5. Replace the door carefully to avoid dislodging the gasket.

Cleaning The Glass

The glass may be cleaned with ordinary household glass cleaner and a soft cloth or paper towel.

Note: Never clean the glass when it is hot. Do not use abrasive cleaners on the glass.

CLEANING THE LOG SET AND FIREBOX.

During the annual inspection and maintenance appointment, the service person should clean dust, lint and any light soot accumulation from the logs and the firebox area. An extra soft brush should be used on the logs, as they are extremely fragile. If at any time the logs cannot be removed or installed without force, the cause must be found. The logs must never be forced.

Procedure,

1. Remove front door as described on page 11.
2. Remove the complete log set from the firebox by lifting it up and out. Brush it gently over a newspaper and carefully place it out of the way.
3. The bark tray can be removed by lifting its feet over the bottom gasket retainer and pulling it straight out, with the bark still on it.
4. The bark consists of a mixture of vermiculite and composite chips and it can be dusted by sieving. If needed a replacement bag can be ordered through your YUNCA dealer.
(See parts list for reference number)
5. With firebox empty a vacuum cleaner can be used to remove any visible dust and lint from within the firebox area.
6. Replace the bark tray.
7. Replace log set and redistribute bark.
8. Replace and relatch the front door and close the side panels.

CLEANING THE TOP AND LOUVRES

The top panel is held in place by four retaining clips, two on the back panel and one on each side. The top panel should only be removed with the side panels closed.

Note: If a flue guard kit has been fitted this will need to be removed at this stage. This is done by sliding the front half up and out and unscrewing the back half from its brackets.

The top panel can be lifted up off the retaining clips, this will take a moderately strong pull.

Slide the top panel up the flue until there is sufficient space to vacuum any dust and lint that may be lying under the panel.

This is also a good time to wipe the front louvers with a soft cloth.

INSPECTING THE VENTING

An inspection of the venting system should be made during the annual service appointment. There must be no blockages and the flue must be in good repair. Any sections that are taken apart for inspection must be reassembled and sealed as required.

CLEANING THE FAN FILTER

This is the one maintenance procedure designed to be carried out by the householder.

It can be cleaned with a brush or vacuum cleaner, and replaced.

HOW TO REMOVE FAN

The fan unit is designed to be removed as an assembly.

The procedure for this is as follows.

1. Turn off and unplug power to unit.
2. Take out four screws that attach the fan-mounting bracket to the base.
3. Reach inside the plinth and disconnect the wiring from the switch, taking note of terminal placement. A wiring diagram appears at the back of this manual.
4. The earth wire must be unplugged and the plastic conduit adapter removed from its retaining bracket.
5. The fan unit will now slide out of the back of the heater.
6. When the fan has been removed it can be disassembled as shown below if needed.

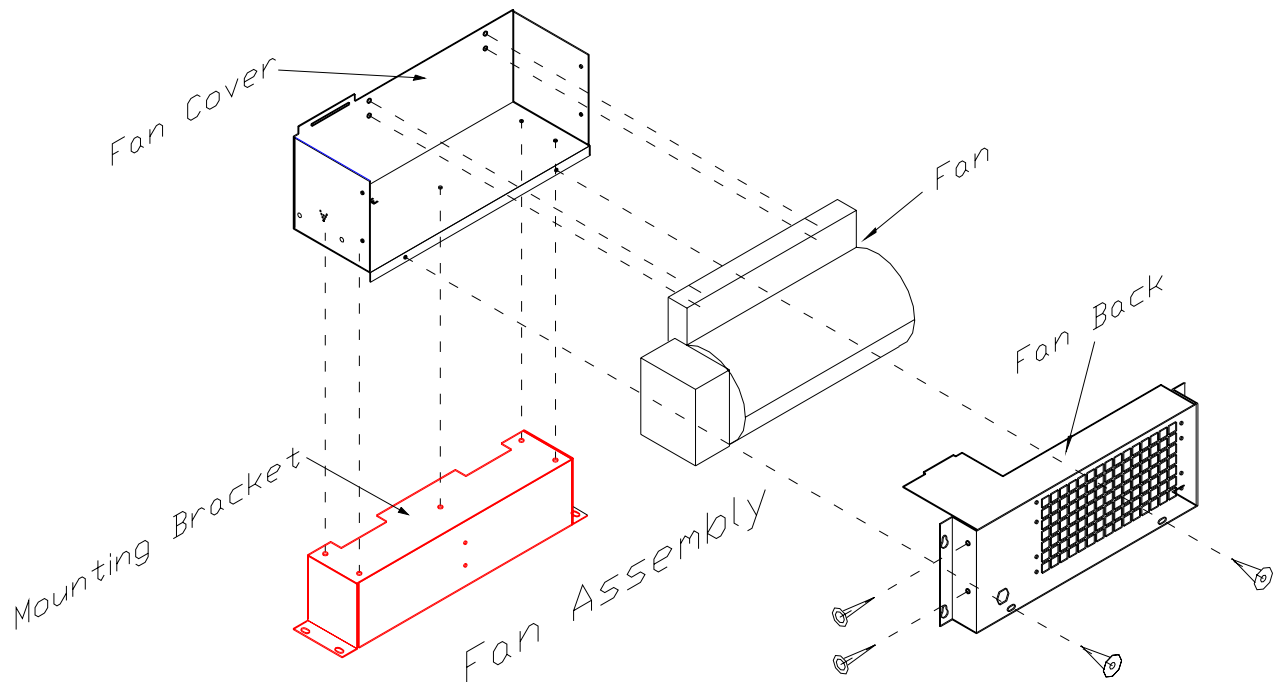

Fault Finding:

SYMPTOM	PROBLEM	CORRECTIVE
Pilot Will Not Light.	<p>No spark at pilot burner.</p> <p>Spark gap is incorrect.</p> <p>No gas at pilot burner</p> <p>No Supply Gas.</p>	<p>Check connection between electrode in pilot assembly and lead from control. Press connection hard together.</p> <p>Replace the pilot assembly if ceramic insulator is cracked or broken</p> <p>Spark gap should be 3-4mm between the electrode tip and the pilot flame hood.</p> <p>Check that isolating valves are turned on and gas is available.</p> <p>Check pilot hood for blockage</p> <p>Remove pilot jet and blow clean. The jet is located inside the base of the pilot burner and is removed by disconnecting the gas to the pilot and removing the brass nut from the base of the burner. Jet will fall out.</p> <p>Check for any obstructions in the gas line that may cause low pressure or restrict flow.</p> <p>Purge gas lines.</p> <p>L.P.G. -- Refill tank Natural -- Check with gas supplier.</p>

<p>Soot is being deposited on glass or logs.</p>	<p>There is insufficient secondary air in the combustion chamber.</p> <p>The logs are not properly positioned.</p> <p>Incorrect gas pressures.</p>	<p>Check the back of the heater for blockages around the air intake slots.</p> <p>Check that the clearances around the heater match those stated in this manual.</p> <p>Ensure that the front log set is sitting flat with no bark chips under it and that the locating pins are in their holes.</p> <p>Check that the back log is sitting on its brackets.</p> <p>Check and set gas pressure to manufacturers specifications.</p>
<p>Main burners extinguishing.</p>	<p>Flue down draughting.</p> <p>Flueway blocked</p> <p>Pilot flame is not large enough.</p> <p>Severe down draught.</p>	<p>This is caused by a vacuum in the room. Turn off heater. Turn off all air conditioners, expelair fans, other heaters etc. Open doors and windows to allow pressure to equalise. Re-light heater. Close doors and windows but not completely.</p> <p>Remove blockage.</p> <p>Check that pilot assembly is correctly mounted and that the pilot burner flame hood directs the pilot flame over both burners and the thermocouple.</p> <p>If the flame pattern is disturbed during extreme winds then ensure a recommended flue cowl has been fitted and is still in place.</p>

<p>Pilot will not stay lit</p>	<p>Incorrect operation.</p> <p>Weak or improperly located pilot flame.</p> <p>Thermocouple not properly connected.</p> <p>Defective thermocouple.</p> <p>Faulty control valve.</p>	<p>Operator not following correct lighting procedure, see lighting instructions.</p> <p>Adjust the height of the thermocouple (using the brass nut at its base) The flame should engulf the top 8mm of the thermocouple.</p> <p>Check back of main control where thermocouples copper tube enters the control. Tighten brass collar nut.</p> <p>Replace thermocouple A new thermocouple may be ordered through your YUNCA agent. (See parts list.)</p> <p>A replacement may be fitted by a suitably qualified service person. (See parts list).</p>
<p>Pilot burning no gas to burners</p>	<p>Burner injectors may be blocked.</p> <p>Faulty control</p>	<p>Disconnect gas supply at burners and unscrew brass injectors from end of burner. Use compressed air to clean out orifice.</p> <p>Control requires replacement.</p>
<p>Back burner stays on when switched to off position.</p>	<p>Build up on the control valve.</p>	<p>Disassemble the control valve by removing the two screws below the cover. Extract the control valve, note the position. Clean the control valve clean and re-assemble. Test operation.</p>

APPENDIX A: GAS TYPE CONVERSION

If at any stage the heater is required to run on a gas other than that which it was factory equipped a conversion kit can be ordered through your YUNCA dealer, see parts list for reference number.

The conversion should be done by a suitably qualified person.

Step 1. Isolate the heater from the gas supply

2. Remove the front door as described on page 11
3. Remove the log set assembly and bark tray.
4. Disconnect the burners from their supply pipes.
5. Unscrew the brass injector holders from the burner frame.
6. The brass injectors are threaded into the end of the injector holders, they can be removed with a 7mm spanner, and the new injectors fitted.
An approved sealing compound should also be used.
7. The burner module can be unscrewed, it is held in place by three screws located between the burners.

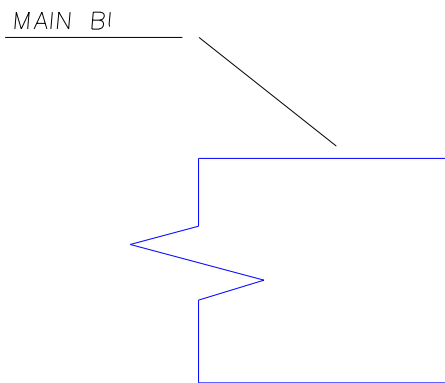

8. The pilot assembly must be removed from the burner module. To do this undo the screw on the left-hand end of the burner support bracket and slide the pilot assembly down. The two screws that attach the pilot assembly are now accessible under the front burner, remove these screws.
9. It is now possible to remove the entire main burner module.
10. This will expose the pilot assembly and make it possible to disconnect the gas

supply to the pilot burner

11. When the brass nut is removed from the base of the pilot burner the pilot jet will drop out. Insert new pilot jet from conversion kit ensuring the chamfered end is facing upwards.
12. The gas can now be reconnected to the pilot and the burner module replaced and reconnected.
13. When changing from N.G. to LPG, the in line restrictor, located in the rear burner pipe where it attaches to the control, must be removed. When changing from LPG to NG, this restrictor must be placed in rear burner pipe at the control.
14. The brass reducer that couples the front burner pipe to the control must also be changed and the reducer supplied with kit fitted.
15. Test all connections for gas tightness and replace logs and door.
16. Update or replace appliance data plate for new specifications and gas type.

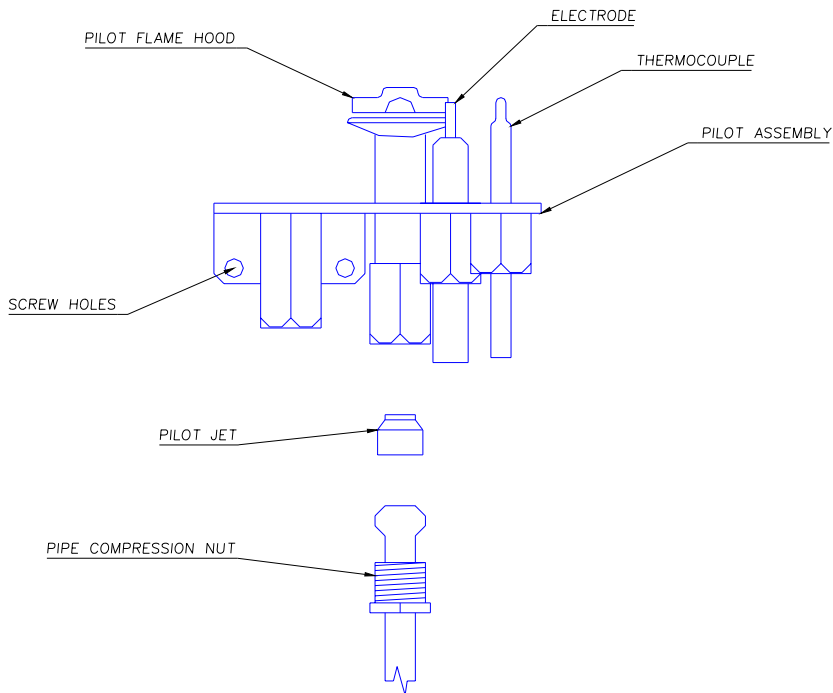

APPENDIX B:

PARTS LIST:

PART NO.	PART NAME
LZ-G01	Mertik gas control
LZ-2011	Burner module
6601	Rear Burner - SIT W-351120
E 7	Front Burner -Furi316
LZ-G03	Pilot assembly
LZ-G04	Electrode
LZ-G05	Thermocouple
LZ-G07	Pilot pipe assembly
LZ-G08	Front burner pipe assembly
LZ-G09	Rear burner pipe assembly
LZ-G10	Adjustable N.G. inline regulator
E 14	Otago Bay Log Set assembly
LZ-G17	Bag of vermiculite
LZ-B11	Door gasket
LZ-B25	Front glass
LZ-B26	Side glass
1950	Booster fan assembly
1955	Rocker switch
8800LF2R	Right side panel (state Colour)
8800LF2L	Left side panel (state Colour)
8300LF2	Top panel (state Colour)
8900LF2	Main door (state Colour)
LZ-A15	L.P.G. conversion kit
LZ-A16	Natural gas conversion kit
LZ-A17	Propane conversion kit
LZ-A08C	Enamelled combustion wrap

APPENDIX C

INJECTOR SIZE:

GAS TYPE	FRONT BURNER	BACK BURNER
NATURAL	2.3mm diameter	2.8mm diameter
L.P.G. (NZ only)	1.15mm diameter	1.15mm diameter
PROPANE	1.20mm diameter	1.20mm diameter
NZ Australia	1.1mm diameter	1.1mm diameter

APPENDIX D: Warranty:

The Yunca Leedz Inbuilt Gas Heater is covered by a limited Five-Year Warranty against defects in materials and workmanship.

All gas and electrical components including control, burners, pilot assembly, tubing, fan and switchers are warranted for a period of one year from date of purchase.

Glass and surface coatings are also warranted for one year.

Damage caused by neglect, improper use, acts of god, theft, or any other indirect, incidental cause are not covered by this warranty.

This warranty is void if the recommended service schedule is not implemented as suggested in this manual and carried out by a suitably qualified person.

Limitations of Liabilities:

Yunca Heating hereby waives any liability for incidental and consequential damage directly or indirectly sustained, or for any loss caused by the application of this product not in accordance with the current printed instructions.

Our liability is expressly limited to replacement of defective goods as per above warranty. Any claim shall be deemed waived unless made in writing to Yunca within 30 days from the date that it was or reasonably should have been discovered.

APPENDIX E: Fan Wiring Diagram:

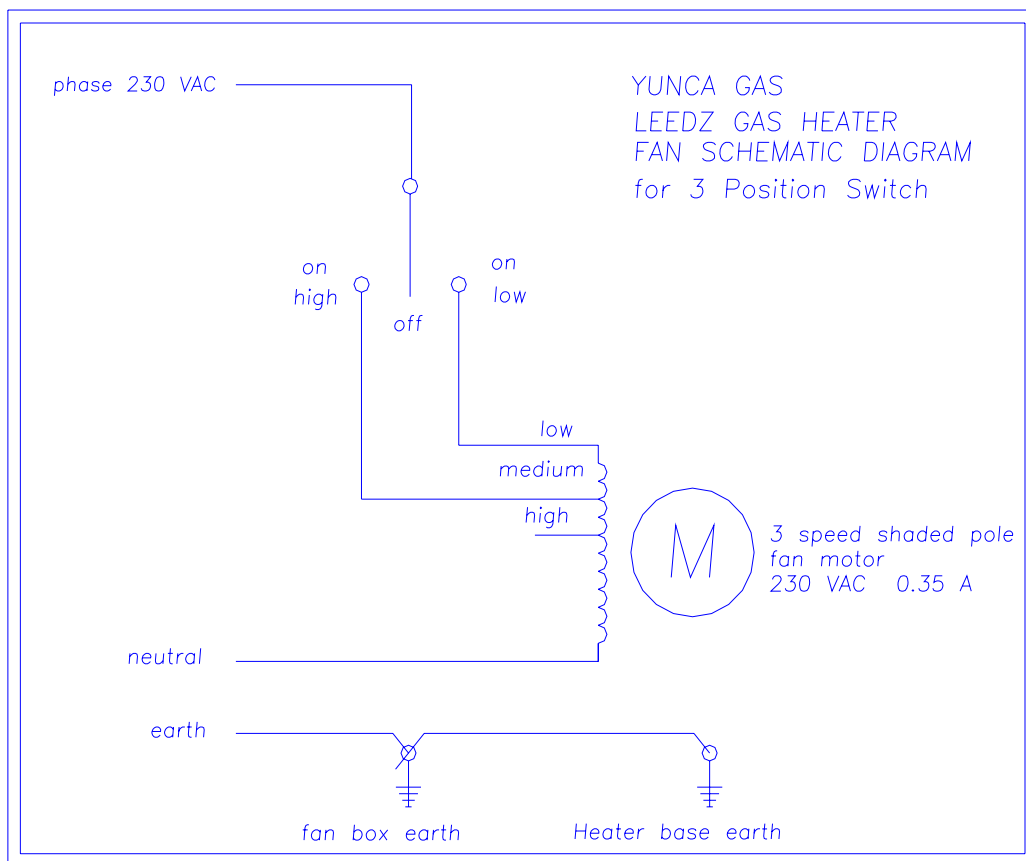

CUSTOMER COPY
YUNCA LEEDZ WARRANTY REGISTRATION:

Serial No. _____ **Gas Type.** _____ **Purchase Date** _____

Purchasers' Name. _____

Purchasers' Address. _____

City. _____ PostCode. _____ Telephone _____

Where Purchased. _____

Installed By. _____ **Date.** _____

Yunca Gas Dunedin
PO Box 500
DUNEDIN
Telephone (03) 488 4342

Cut along here...

This section must be returned within 10 days of purchase.

YUNCA LEEDZ WARRANTY REGISTRATION:

Serial No. _____ **Gas Type.** _____ **Purchase Date** _____

Purchasers' Name. _____

Purchasers' Address. _____

City. _____ PostCode. _____ Telephone _____

Where Purchased. _____

Installed By. _____ **Date.** _____

Return to: Yunca Heating
PO Box 932
INVERCARGILL